

# WORKS BARRICADE BOARDS

BLOW MOLDED PLASTIC PANELS

**TD4300 MODEL**

**NCHRP350 CRASH TEST CERTIFIED  
AND MEETS MUTCD STANDARDS**

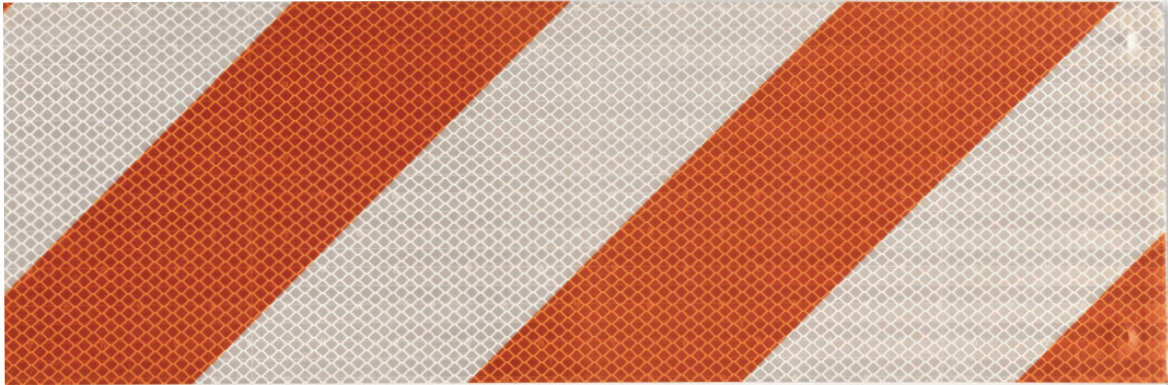

- High Impact Blow Molded plastic panels are reinforced to reduce bending and warping in hot weather and will withstand the strongest of impacts.
- Unique rib pattern provides improved board strength, durability and rigidity.
- Boards are provided with molded bolt holes that accept common 1/4" bolts.
- Type I and Type II barricade boards available in 6" X 24", 8" X 24" and 12" X 24" sizes.

**NCHRP350 Approved: WZ-54**

All sheeting complies with  
ASTM 4956 requirements.

#### GENERAL INFORMATION:

General information is listed on the reverse side. The measurements provided are intended only as a source of information. They are given without guarantee and are not classified as a warranty. A specification will be sent to you upon request.



*we got the works!!*  
**Three D TrafficWORKS**  
Innovative Traffic Safety Products



430 N. Varney Burbank, CA. 91502 Tel: (877) 843-9757 Fax: (818) 841-5096  
Email: sales@trafficwks.com Web: trafficwks.com



## TD4300 MODEL

### WORKS BARRICADE BLOW MOLDED PLASTIC PANELS

#### SPECIFICATIONS

- Dimensions:  
 Thickness: 0.556"  
 Length: 24.00"  
 Width: 6", 8" and 12"
- Board color is White.
- Weight:  
 6" X 24" weighs 1.5 lbs.  
 8" X 24" weighs 2 lbs.  
 12" X 24" weighs 2.75 lbs.
- All sheeting complies with ASTM 4956 requirements.
- Plastic Board Material: UV Stabilized Polymer Compound with 90% Recycled Content.

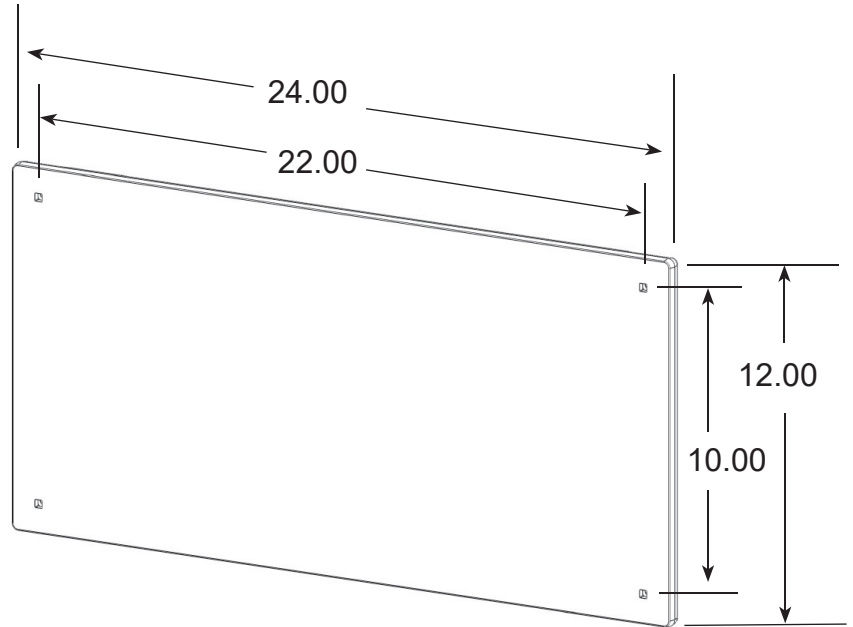

12" X 24" Board

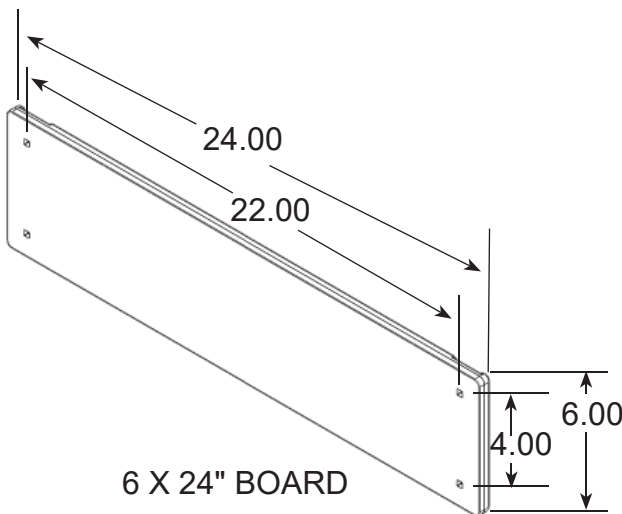

6 X 24" BOARD

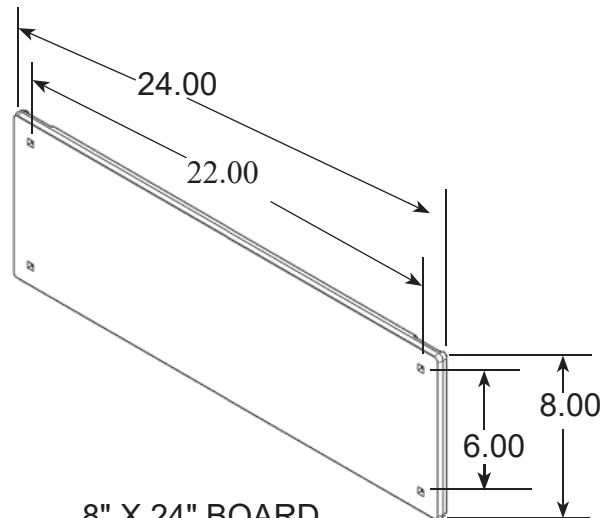

8" X 24" BOARD